



HP75NN  
Shown

## Features

- **Pump Design** – Compact, close coupled, light weight
- **Pump Body** – Non-metallic Noryl
- **Versatility** – Multiple O-ring materials
- **Motor shaft** – Threaded

## Applications

- Chillers / Liquid Cooling
- Chemical Processing
- Booster Pumps
- Water Purification
- Circulation / Filtration
- Air Conditioning / Heat Recovery

## Optional Configurations

- **Power Frame Mounting:**

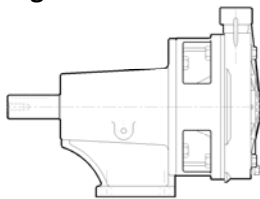

- **Long-Coupled Mounting:**

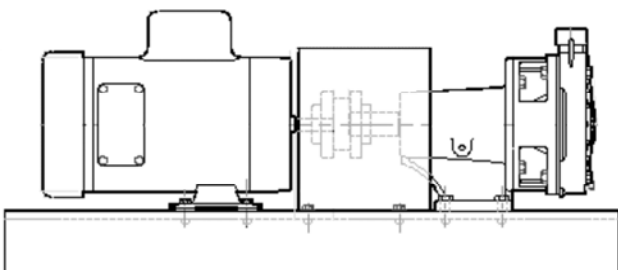

## HP75NN (O-ring Design)

### Pump Volute / Impeller Materials

HP75NN – Noryl / CPVC

## Standard Specifications

- HP75NN Discharge 3/4" FNPT, Suction 3/4" FNPT
- Maximum Impeller Diameter: 4.50"
- Motor: NEMA 56J Footless (Multiple enclosures available)
- Mechanical Seal:
  - Single, 5/8" Type 6 Buna, Carbon vs. Ceramic
  - Note: Additional seal options available*
- O-ring Material: Buna (Viton, EPR, & Neoprene optional)
- Bracket Material: Noryl

## Performance Curve – 60 Hz

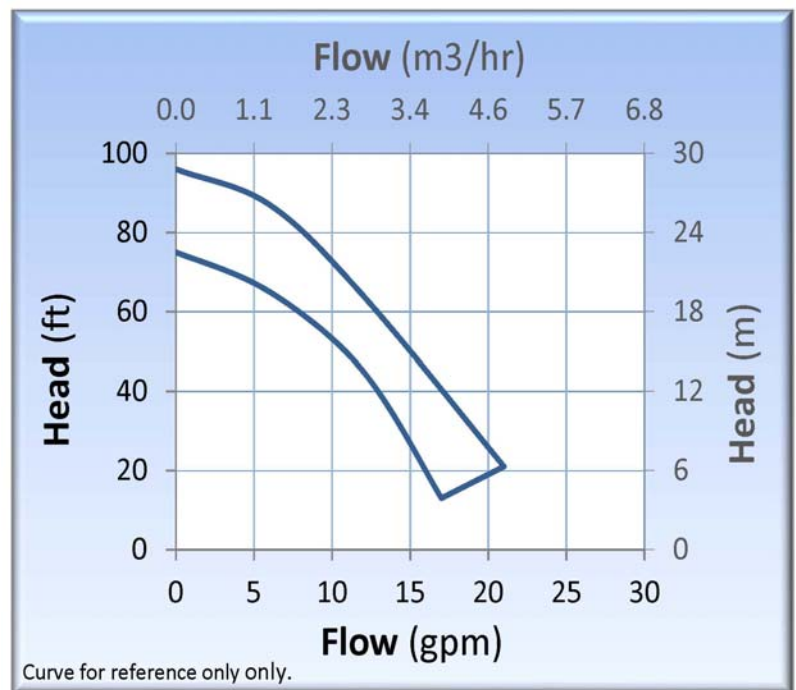

# HP75NN (O-ring Design)

| Technical Information |                      |
|-----------------------|----------------------|
| Max Flow              | 20 GPM (4.5 m3/hr)   |
| Max Head              | 90 feet (27.4 m)     |
| Min. Flow             | 0.5 GPM (0.12 m3/hr) |
| Max Solid Size        | 0.030" (0.76 mm)     |
| Max Working Pressure  | 40 PSI (2.75 bar)    |
| Max Temp. (SC)        | 140°F (60°C)*        |

\* Temperature limits are based on standard seal and O-ring materials, and will vary according to the liquid being pumped.

| Materials of Construction |  |
|---------------------------|--|
| HP75NN                    |  |
| Volute                    | NORYL                                  |
| Impeller                  | CPVC                                   |
| Bracket                   | NORYL                                  |
| Fasteners                 | Steel-Zinc Plated                      |
| O-ring                    | Buna (Viton, EPR, & Neoprene optional) |

## Dimensions (HP75 Noryl)

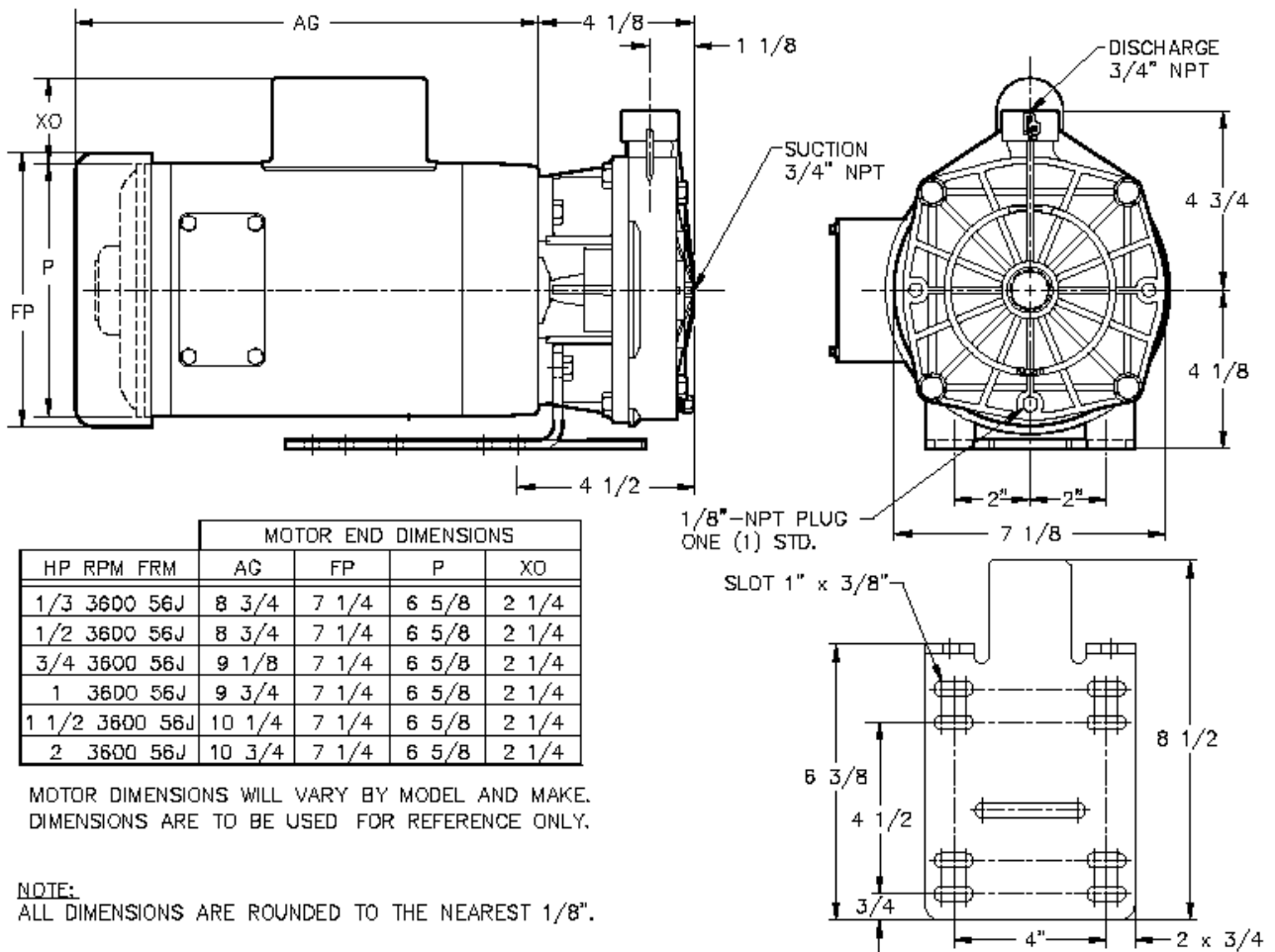

Contact factory for special pump configurations,  
same day, and next day delivery options.



21775 Eighth Street East  
Sonoma, CA 95476-0329  
MAIN (707) 938-8441  
TOLL FREE (800) 345-7867  
FAX (707) 938-0764  
E-mail: [sales@pricepump.com](mailto:sales@pricepump.com)  
Website: [www.pricepump.com](http://www.pricepump.com)



Rev. - Date: May 2011