

REPAIR AND MAINTENANCE

For Type 21:

a. Lubricate shaft and elastomer with vegetable oil or equivalent.

b. Install first rotary seal head onto pump shaft and slide toward seat using a twisting motion until carbon face touches seal seat.

c. Install second rotary seal head onto shaft sleeve with carbon facing towards pump end.

8. Install seal plate onto pump end of bracket with new gasket and tighten cap screws evenly (note: use pipe sealant on bolts).

9. Install impeller:

a. Install key in pump shaft.

b. Slide impeller onto shaft.

c. Install impeller washer and lockdown. Tighten to 10 ft-lbs.

10. Loosen pump shaft set screw.

11. Install new volute gasket or o-ring and mount volute. Secure with bolts and tighten evenly.

12. Move shaft back with a screw driver **.010"-.015"**. Tighten pump shaft set screws. Turn shaft by hand to ensure impeller does not rub against volute.

13. Return pump to installation, reconnect electric connections.

14. Start pump momentarily to observe shaft rotation. If rotation corresponds to the

rotation arrow on the pump, it may be put into service. If rotation is incorrect, switch any two leads on 3-phase motors to change rotation. Check wiring diagram of motor for single phase rotation correction.

15. Remove top pipe plug (if applicable) from the front of volute and prime pump thoroughly, making sure all air is purged. Turn shaft one revolution and then refill. Replace the pipe plug.

16. Start pump allowing adequate time to purge all air from system. Observe any gauges, flow meters, etc., to see if pump performs properly.

Double Seal Flush Piping Installation

1. Piping of the double seal arrangement should be done in accordance with all governmental regulations and safety codes.

2. All double seals require a barrier flush between the seals for proper lubrication and cooling. The barrier liquid must be maintained at 10-15 PSIG above the discharge pressure of the pump and it must be chemically compatible with the pumped liquid, material construction of the pump,

and seals (5/8" double seals have 18-8 parts).

3. The barrier flush shall have a minimum flow rate in accordance with the graph below. If water is used as a fluid, the inlet temperature should not exceed 140°F.

4. A positive pressure must be maintained to the barrier flush between the seal faces even when the pump is not running. To conserve the barrier liquid a solenoid

valve (Item 1) may be installed and connected electrically in parallel with the motor so the barrier fluid flows only when the pump is running. Note: The maximum pressure of the barrier fluid at the inlet is 150 PSIG.

5. The inlet should be connected to the bottom and the outlet to the top of the seal cavity.

REPAIR AND MAINTENANCE

Procedures for Checking Double Seals for Internal Leakage

Option 1 - for use with 2 flow meters.

Install flow meters on the inlet and outlet lines. Normal operating conditions will be indicated by equal or near equal flow on both flow meters. If the inlet flow meter shows more flow than the outlet, this could indicate excessive leakage.

Option 2 - for use with 1 flow meter.

1. Shut off flow at outlet needle valve (Item 2).
2. Shut off inlet gate valve (Item 8) - for 15 seconds maximum.
3. If pressure in seal cavity drops rapidly rather than gradually while the gate valve is shut, the seal is leaking excessively.
4. To restart open gate valve first then reset valve on outlet.

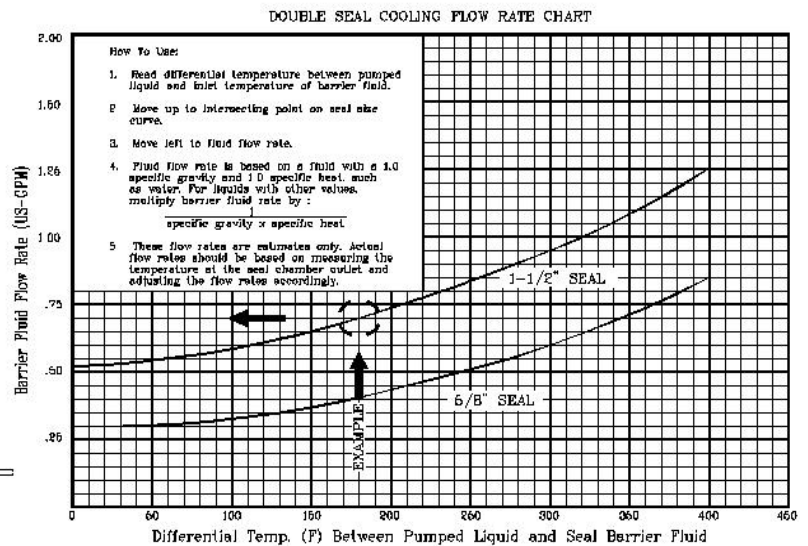
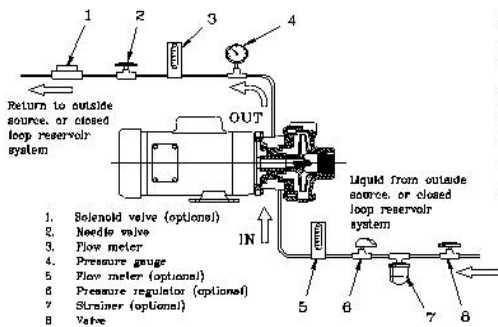

ART-010



PRICE PUMP CO.

LT25_P.dwg rev. A

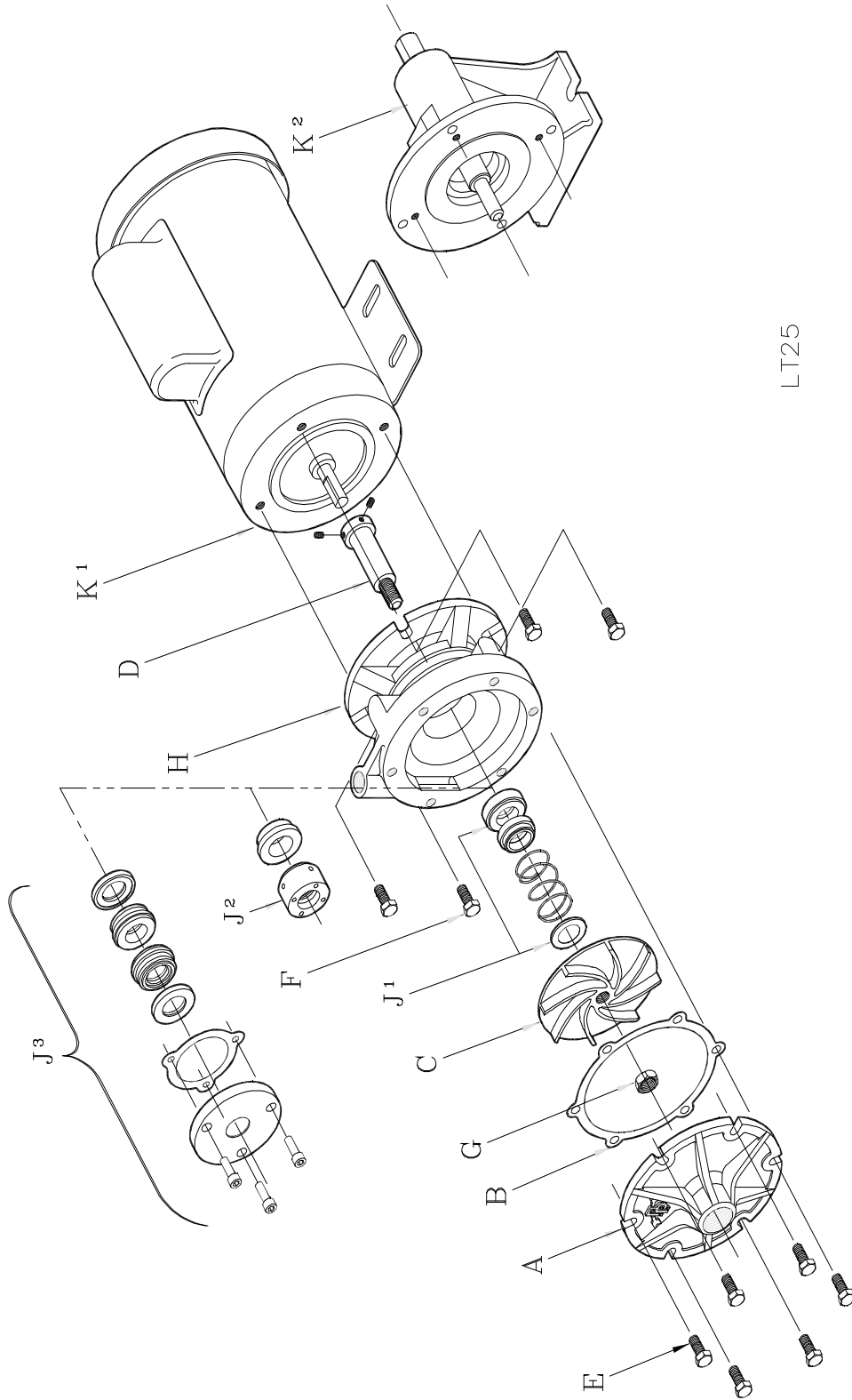

LT25

Price Pump Co.
2203 Smeed Parkway * Caldwell, ID 83605 * (208) 402-6871 * Fax (208) 402-6856

PRICE CENTRIFUGAL PUMP CAUTIONS & WARNINGS

- **CAUTION:** Price Pump centrifugal pumps must be operated above minimum flow rate to avoid damage.
- **CAUTION:** All Price Pump centrifugal pumps require the suction to be flooded.
- **CAUTION:** It is recommended that all piping connections to the pump be flexible.
- **WARNING:** Verify chemical compatibility of the pump materials of construction with the fluid being pumped.
- **WARNING:** Price centrifugal pumps are not designed for use in sanitary or food applications.
- **CAUTION:** Use only Price Pump original equipment factory replacement parts.
- **WARNING:** Price pump fluid temperature limits must be observed. Maximum operating temperature is 300°F.
- **CAUTION:** The pump should be thoroughly flushed and drained before disassembly.
- **CAUTION:** For larger pump motor units, weight may exceed 65 lbs. (30 kg).

CAUTION: Maximum working pressure for seals:

- | | |
|------------------|---------------------------|
| ○ Type 6 Seal | 75 PSI (5.2 bar) |
| ○ Type 6A Seal | 75 PSI (5.2 bar) |
| ○ Type 8 Seal | 325 PSI (22.4 bar) |
| ○ Type 9 Seal | 350 PSI (24.1 bar) |
| ○ Type 21 Seal | 150 PSI (10.3 bar) |
| ○ Type 2106 Seal | 150 PSI (10.3 bar) |

CAUTION: Maximum solid size by pump

- | | |
|---------------|------------------------|
| ○ HP75 / MS50 | 0.030" (0.76mm) |
| ○ SP150 | 0.060" (1.50mm) |
| ○ LT25 | 0.120" (3.05mm) |
| ○ F50/75/95 | 0.150" (3.81mm) |
| ○ OH75 | 0.150" (3.81mm) |
| ○ CD100/150 | 0.150" (3.81mm) |
| ○ CL150 | 0.150" (3.81mm) |
| ○ RC200/300 | 0.380" (9.60mm) |
| ○ XJ-JB100 | 0.120" (3.05mm) |
| ○ XJ-JB150 | 0.250" (6.40mm) |
| ○ XJ-JB200 | 0.440" (11.2mm) |
| ○ XL-XT100 | 0.120" (3.05mm) |
| ○ XL-XT150 | 0.250" (6.40mm) |
| ○ XL-XT200 | 0.440" (11.2mm) |

CAUTION: Minimum flow rate by pump

- | | |
|---------------|--------------------------|
| ○ HP75 / MS50 | 0.5 GPM (1.9 LPM) |
| ○ SP150 | 10 GPM (38 LPM) |
| ○ LT25 | 0.5 GPM (1.9 LPM) |
| ○ F50/75/95 | 5.0 GPM (19 LPM) |
| ○ OH75 | 7.0 GPM (26 LPM) |
| ○ CD100 | 12 GPM (45 LPM) |
| ○ CD150 | 25 GPM (94 LPM) |
| ○ CL150 | 40 GPM (150 LPM) |
| ○ RC200 | 10 GPM (38 LPM) |
| ○ RC300 | 50 GPM (189 LPM) |
| ○ XJ-JB150 | 20 GPM (75 LPM) |
| ○ XJ-JB150 | 40 GPM (150 LPM) |
| ○ XJ-JB200 | 90 GPM (340 LPM) |
| ○ XL-XT100 | 10 GPM (38 LPM) |
| ○ XL-XT150 | 35 GPM (132 LPM) |
| ○ XL-XT200 | 50 GPM (189 LPM) |



GENERAL TERMS OF SALE

1. GENERAL

A. Seller's price is based on these sales terms and conditions. The agreement and inclusion of other or amended terms in this contract will result in a change (including increase) in Seller's price (as may be contained in any price books or quotations) to reflect such other or amended terms. This contract shall represent the final, complete and exclusive statement of the agreement between the parties and may not be modified, supplemented, explained or waived by parole evidence, any Terms and Conditions contained in Buyer's purchase order or request for quotation, any course of dealings between the parties, Seller's performance or delivery, or in any other way. The Terms and Conditions of this contract may only be modified or waived in a written document signed by an Officer of Seller. These terms are intended to cover all activity of Seller and Buyer hereunder, including sales and use of products, parts and work and all related matters (references to products include parts and references to work include construction, installation and start-up). Any reference by Seller to Buyer's specifications and similar requirements are only to describe the products and work covered hereby and no warranties or other terms therein shall have any force of effect. Any information provided by Seller including, but not limited to, suggestions as to specific equipment does not imply any guarantee of specific suitability and/or material compatibility in a particular application, since many factors outside the control of Seller may affect the suitability of products in a particular application. Catalogs, circulars, similar pamphlets and information contained on websites of the Seller are issued for general information purposes only and shall not be deemed to modify the provisions hereof.

B. The agreement formed hereby and the language herein shall be construed and enforced under the Uniform Commercial Code as in effect in the State of California on the date hereof.

2. TAXES

Any sales, use or other similar type taxes imposed on this sale or on this transaction and/or any import or export duties or fees as may be assessed or imposed on or as a result of deliveries under this transaction are not included in the price. Such taxes shall be billed separately to the Buyer. Seller will accept a valid exemption certificate from the Buyer if applicable; however, if an exemption certificate previously accepted is not recognized by the governmental taxing authority involved and the Seller is required to pay the tax covered by such exemption certificate. Buyer agrees to promptly reimburse Seller for the taxes paid.

3. PERFORMANCE, INSPECTION AND ACCEPTANCE

A. Unless Seller specifically assumes installation, construction or start-up responsibility, all products shall be finally inspected and accepted within thirty (30) days after arrival at point of delivery. Where seller has responsibility for installation, construction or start-up all work shall be finally inspected and accepted within thirty (30) days after completion of the applicable work by Seller. All claims whatsoever by Buyer, (including claims for shortages) except only those provided for under the WARRANTY AND LIMITATION OF LIABILITY and PATENTS Clauses, hereof, must be asserted in writing by Buyer within said thirty (30) day period or they are waived. If this contract involves partial performance, all such claims must be asserted within said thirty- (30) day period for each partial performance. There shall be no revocation of acceptance. Rejection may be only for defects substantially impairing the value of products or work and Buyer's remedy for lesser defects shall be those provided for under the WARRANTY AND LIMITATION OF LIABILITY Clause.

B. Seller shall not be responsible for non-performance or for delays in performance occasioned by any causes beyond Seller's reasonable control, including, by way of example and not limitation, to labor difficulties, delays of vendors or carriers, fires, governmental actions, or shortages of material, components, labor, or manufacturing facilities. Any delays so occasioned shall affect a corresponding extension of Seller's performance dates, which are, in any event, understood to be approximate. IN NO EVENT SHALL BUYER BE ENTITLED TO INCIDENTAL OR CONSEQUENTIAL DAMAGES FOR LATE PERFORMANCE OR FOR A FAILURE TO PERFORM. Seller reserves the right to make partial shipments and to ship products, parts or work which may be completed prior to the scheduled performance date.

C. In the event that Seller has agreed to mount motors, turbines, gears, or other products which are not manufactured by Seller and which are not an integral part of Seller's manufactured product, and a delay in the delivery of such products to Seller occurs that will cause a delay in Seller's performance date, Seller reserves the right to ship its product upon completion of manufacture and to refund an equitable portion of the amount originally included in the purchase price for mounting without incurring liability for non-performance.

D. Seller reserves to itself the right to change its specifications, drawings and standards if such changes will not impair the performance of its products, and parts, and further those products, and parts, will meet any of Buyer's specifications and other specific product requirements which are a part of this agreement. Seller is a global supplier of products and utilizes parts and products obtained worldwide, and Seller's products supplied under this contract shall be subject to Seller's sole determination as to all manufacturing, sourcing, assembly and supply unless otherwise specifically agreed in writing.

E. The manufacture and inspection of products and parts shall be to Seller's Engineering and Quality Assurance standards, plus such other inspections or tests of documentation as are specifically agreed to by Seller. Requirements for any additional inspection, tests, documentation, or Buyer witness of manufacture, test, and/or inspection shall be subject to additional charges.

4. TITLE AND RISK OF LOSS

Title and risk of loss shall pass to buyer upon delivery of products at the designated "Ex Works" as defined by Incoterms, unless otherwise agreed by the parties.

5. EROSION AND CORROSION

It is specifically understood that products and parts sold hereunder are not warranted for operation with erosive or corrosive fluids or for operation with any fluid or under any operating condition in variance with the specifications of this contract. No product or part shall be deemed to be defective by reason of failure to resist erosive or corrosive action of any fluid and Buyer shall have no claim whatsoever against Seller therefore. No product shall be deemed defective by reason of any effect on Seller's products of the action or results (such as vibration) of any goods or system (such as piping) not supplied by Seller.

6. BUYER'S RESPONSIBILITY

The design specifications of the equipment require the operation of the equipment within certain parameters and may call for the use of speed controls, safety devices, set points or other control devices to insure that the operation remains within design parameters. Buyer agrees and understands that the equipment must be operated and maintained within design specifications and operated within the specifications of the contract, irrespective of whether controls or devices are otherwise required.

7. WARRANTY AND LIMITATION OF LIABILITY

A. Seller warrants only that its product and parts, when shipped, will be free from defects in materials and workmanship. All claims for defective products or parts under this warranty must be made in writing immediately upon discovery and, in any event, within two (2) years of shipment by seller and all claims for defective work must be made in writing immediately upon discovery. Defective items must be held for Seller's inspection and returned to the sellers' point of original shipment upon request.

ANY UNAUTHORIZED DISSASSEMBLY, ALTERATION OF OR TAMPERING WITH ANY PRODUCT OR COMPONENT MAY "VOID" THE WARRANTY, IN THAT SUCH ACTION WILL RESULT IN SELLER BEING RELEASED AND RELIEVED FROM ITS OBLIGATIONS UNDER THIS WARRANTY AND FOR ANY FURTHER COSTS OR ACTIONS UNDER CLAUSE 7.C, FOLLOWING, AND THE BUYER ASSUMING SOLE RESPONSIBILITY FOR THE COSTS AND RESULTS OF SUCH ACTION. THE FOREGOING IS EXPRESSLY IN LIEU OF ALL OTHER WARRANTIES WHATSOEVER, EXPRESS, IMPLIED AND STATUTORY, INCLUDING WITHOUT LIMITATION, THE IMPLIED, WARRANTIES OF MERCHANTABILITY AND FITNESS.

B. ANY PRODUCT (S) SOLD HEREUNDER WHICH ARE NOT MANUFACTURED BY SELLER ARE NOT WARRANTED BY SELLER and shall be covered only by the express warranty, if any, of the manufacturer thereof. With respect to products and parts not manufactured by Seller, Seller's only obligation shall be to assign to Buyer, to the extent possible, whatever warranty Seller obtains from the manufacturer.

C. Upon Buyer's submission of a claim as provided above and its substantiation, Seller shall at its option either (i) repair or replace its product, part or work at the original place of shipment, or (ii) refund an equitable portion of the purchase price.

D. THE FOREGOING IS SELLER'S ONLY OBLIGATION AND BUYER'S EXCLUSIVE REMEDY FOR BREACH OF WARRANTY AND, EXCEPT FOR THE REMEDIES PERMITTED UNDER THE PERFORMANCE, INSPECTION AND ACCEPTANCE AND THE PATENTS CLAUSES HEREOF, THE FOREGOING IS BUYER EXCLUSIVE REMEDY AGAINST SELLER FOR ALL CLAIMS ARISING HEREUNDER OR RELATING HERETO WHETHER SUCH CLAIMS ARE BASED ON BREACH OF CONTRACT, TORT (INCLUDING NEGLIGENCE OR STRICT LIABILITY), INDEMNITY OR OTHER THEORIES. BUYER'S FAILURE TO SUBMIT A CLAIM AS PROVIDED ABOVE SHALL SPECIFICALLY WAIVE ALL CLAIMS FOR DAMAGES OR OTHER RELIEF, INCLUDING BUT NOT LIMITED TO CLAIMS BASED ON LATENT DEFECTS. IN NO EVENT SHALL BUYER BE ENTITLED TO INDIRECT, SPECIAL, INCIDENTAL OR CONSEQUENTIAL DAMAGES, NOR FOR DAMAGES FOR LOSS OF USE, LOST PROFITS OR REVENUE, INTEREST, LOST GOODWILL, WORK OR PRODUCTION STOPPAGE, IMPAIRMENT OF OTHER GOODS, INCREASED EXPENSES OF OPERATION, OR THE COST OF PURCHASING REPLACEMENT POWER OR OTHER SERVICES BECAUSE OF SERVICE INTERRUPTIONS. FURTHERMORE, IN NO EVENT SHALL SELLER'S TOTAL LIABILITY FOR DAMAGES OF BUYER EXCEED THE PURCHASE PRICE OF THE PRODUCTS OR PARTS MANUFACTURED BY SELLER AND UPON WHICH SUCH LIABILITY IS BASED. ANY ACTION ARISING HEREUNDER RELATED HERETO, WHETHER BASED ON BREACH OF CONTRACT, TORT (INCLUDING NEGLIGENCE) OR OTHER THEORIES, MUST BE COMMENCED WITHIN ONE (1) YEAR AFTER THE CAUSE OF ACTION ACCRUES OR IT SHALL BE BARRED.

8. PURCHASER'S REPRESENTATIONS & WARRANTIES

Purchaser represents and warrants that the products(s) covered by this contract shall not be used in or in connection with a nuclear facility or application. The parties agree that this representation and warranty is material and is being relied on by seller. This provision may be modified in a separate writing signed by an officer of Price Pump Co.

9. PATENTS

Seller agrees to assume the defense of any suit for infringement of any patents brought against Buyer to the extent of such suit charges infringement of an apparatus or product claim by Seller's product in and of itself, provided (i) said product is built entirely to Seller's design, (ii) Buyer notifies Seller in writing of the filing of such suit within ten (10) days after the service of process thereof, and (iii) Seller is given complete control of the defense of such suit, including the right to defend, settle and make changes in the product for the purpose of avoiding infringement of any process or method claims. Provided however, Seller will not defend any suit for infringement of a claimed patent where such alleged infringement is the result of following specific instruction furnished by Seller.

10. EXTENT OF SUPPLY

Only products as listed in Seller's proposal are included in this agreement. It must not be assumed that Seller has included anything beyond same.

11. MANUFACTURING SOURCES

To maintain delivery schedules, Seller reserves the right to have all or any part of the Buyer's order manufactured at any of Sellers', sellers' licensees or sub contractors' plants, globally.

12. TERMS OF PAYMENT

Net 30 days from date of invoice.

13. ARBITRATION

In the event a dispute arises between the parties relating to or arising out of this agreement, the parties agree to attempt to have their senior management amicably settle the matter. In the event that the matter cannot be settled, the parties shall submit all disputes relating to this Agreement (whether contract, tort, products liability or otherwise) to binding Arbitration before a panel of arbitrators under the Commercial Dispute Resolution Procedures of the American Arbitration Association. Each party shall appoint an arbitrator and the third shall be selected in accordance with the rules of the American Arbitration Association. Judgment upon the award may be entered in any court having jurisdiction. The parties shall cooperate in providing reasonable disclosure of relevant documents. Each party shall bear its own expenses, and the costs and fees of the arbitration shall be borne as allocated by the Arbitrator.