

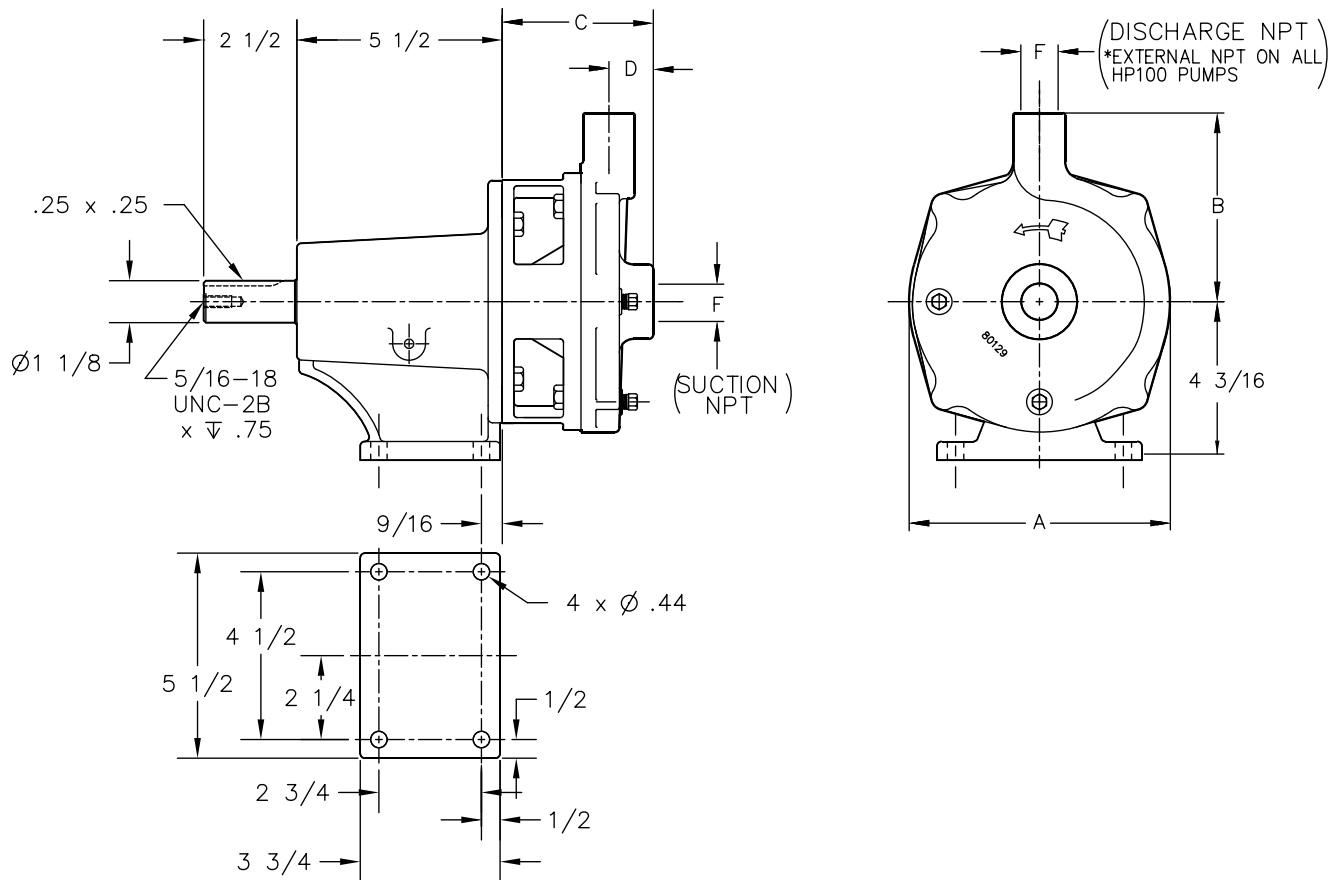

PRICE® PUMP CO.

HP75/HP100 (O-RING DESIGN) POWER FRAME OUTLINE DRAWING

Effective: May19, 2011



NOTE:
ALL DIMENSIONS ARE ROUNDED TO THE
NEAREST 1/16 INCH.

MATERIAL	MODEL	A	B	C	D	F
SS	HP75SS/ HP75SC	6 15/16	5 1/8	4 1/8	1 1/8	3/4
BRONZE	HP75AB	6 15/16	5 1/8	4 1/8	1 1/8	3/4
SS	HP100SS/ HP100SC	6 15/16	5	4 1/8	1 1/8	1
BRONZE	HP100AB	6 15/16	5	4 1/8	1 1/8	1

Price® Pump Co.

21775 Eighth Street East * Sonoma, CA 95476-0329 * (707) 938-8441 * Fax (707) 938-0764